

# SILPIG

## Product Recovery System



### APPLICATION

The PIG system is ideal for the recovery of any product remaining in a pipeline in the end of the transfer process. As this product can be of a high value the PIG system recovers the product removing it from the pipelines and preparing the pipeline for a CIP process. Another benefit is the reduction of the fluid sent to the sewage treatment plant that results in saving energy and water. The main application of the system is viscous media. Among the products treated there are chocolates, marmelades, confectionary creams in the food-processing industry, or gels, creamers and other body care products of high value in the cosmetic industry.

### OPERATING PRINCIPLE

The SILPIG system is designed to recover the remaining product inside a pipeline after the pumping process and/or to remove the product to facilitate subsequent cleaning through a CIP process.

The SILPIG system consists of a sending station, a receiving station, the PIG, two position detectors, four A480 butterfly valves, and two INNOVA K valves.

The process begins by placing the PIG in the launch position. It is propelled toward the receiving station by a driving fluid, usually compressed air. As it moves, the PIG pushes the product inside the pipeline for recovery. Once it reaches the receiving station, the entire system can be cleaned through CIP, with the added advantage that the PIG is also cleaned. After this phase, the PIG is returned to the launch station, and the system is ready for the next production cycle.

### DESIGN AND FEATURES

- Hygienic system
- High level of product recovery.
- PIG can pass through 1.5D bends.

### TECHNICAL SPECIFICATIONS

#### Materials

Parts in contact with the product	1.4404 (AISI 316L)
Other steel parts	1.4301 (AISI 304)
Seals in contact with the product	EPDM (standard) - FPM
PIG	VMQ (standard) - NBR - EPDM

**Surface finish**

Internal	brigh polish Ra ≤ 0,8 μm
External	matt

**Sizes availables**

DIN EN 10357 serie A (formerly DIN 11850 serie 2)	DN 40 - DN 100
--	----------------

ASTM A269/270 (corresponds to OD tube)	OD 1½" - OD 4"
---	----------------

SMS	38-104
-----	--------

**Connections**

male, clamp

**Operating limits**

Maximum working temperature	121°C (250°F) EPDM seals (for highers temperatures other grades of seals will be used)
Maximum working pressure	1000 kPa (10 bar)
Maximum PIG speed	1 m/s
Recommended pressure to push the PIG	100 kPa - 500 kPa (1 - 5 bar) <sup>1</sup>

**Actuator**

Type	Double acting
Compressed air pressure	500 - 700 kPa (5 - 7 bar)
Compressed air fitting	G 1/8 (for tube Ø 6 mm)

1) depending on the product and the working conditions

**OPTIONS**

Control panel.  
90° inlet.  
Heating chamber.

**BENEFITS**

Production downtime reduced.  
Raw materials loss reduced.  
Recovery of up to 98% of the product.  
Effluent reduced.  
CIP cleaning time, water consumption and quantity of chemical products reduced.

## DIMENSIONS

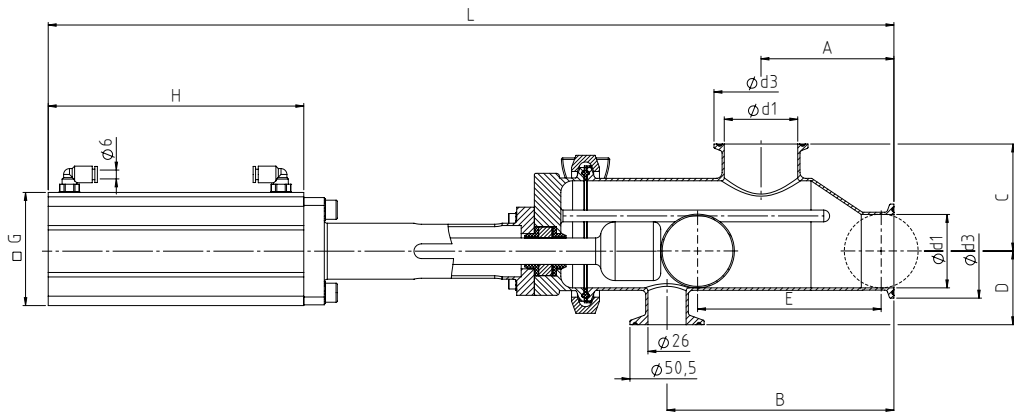

13.001.32.0023

	DN	Ød1	Ød3	A	B	C	D	E	G	H	L
DIN	40	38	50,5	98	161	79	45	125	79	174	577
	50	50	64	90	154	72	50	125	79	174	576
	65	66	91	145	241	110	59	200	79	249	814
	80	81	106	140	244	102	67	200	79	249	822
	100	100	119	160	288	134	77	250	77	371	1089
OD	1½"	34,8	50,5	109	168	87	49	125	79	174	583
	2"	47,5	64	102	165	81	56	125	79	174	586
	2½"	60,2	77,5	148	233	113	63	200	79	249	812
	3"	72,9	91	141	245	106	69	200	79	249	825
	4"	97,4	119	106	289	135	83	250	77	371	1089

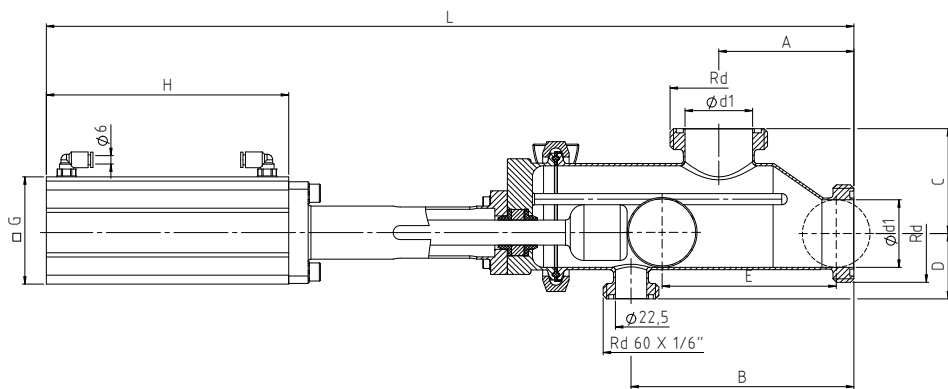

13.001.32.0024

	DN	Ød1	Rd1	A	B	C	D	E	G	H	L
DIN	40	38	65 x 1/6"	110	173	90	52	125	79	174	589
	50	50	78 x 1/6"	104	168	86	57	125	79	174	590
	65	66	95 x 1/6"	157	253	122	67	200	79	249	826
	80	81	110 x 1/4"	157	261	119	74	200	79	249	839
	100	100	130 x 1/4"	186	314	160	85	250	77	371	1115
SMS	38	35,5	60 x 1/6"	104	163	81	40	125	79	174	578
	51	48,5	70 x 1/6"	97	160	75	46	125	79	174	580
	63,5	60,5	85 x 1/6"	147	232	112	53	200	79	249	811
	76	72,9	98 x 1/4"	139	243	105	59	200	79	249	823
	104	100	125 x 1/4"	162	290	136	75	250	77	371	1091